



UNIVERSAL/MULTIFLEX

INTERNATIONAL

Factory Parts Catalog

Product No.	MSBH30V7LS4
Series	28' FDBM
Color	stainless
Volts	220V
Wiring Diagram	242132401
Market	Export
Energy Guide	242224763
Service Data Sheet	242130400

INTERNATIONAL

P.O. BOX 8020
CHARLOTTE, NC 28262

Publication No.
5995639530
13/11/08
(EN/SERVICE/CW)
137

FRENCH DOOR BOTTOM FREEZER/REFRIGERATOR W/O DISPENSER & ICE MAKER

Model No.
MSBH30V7L

FREEZER DRAWER, BASKETS

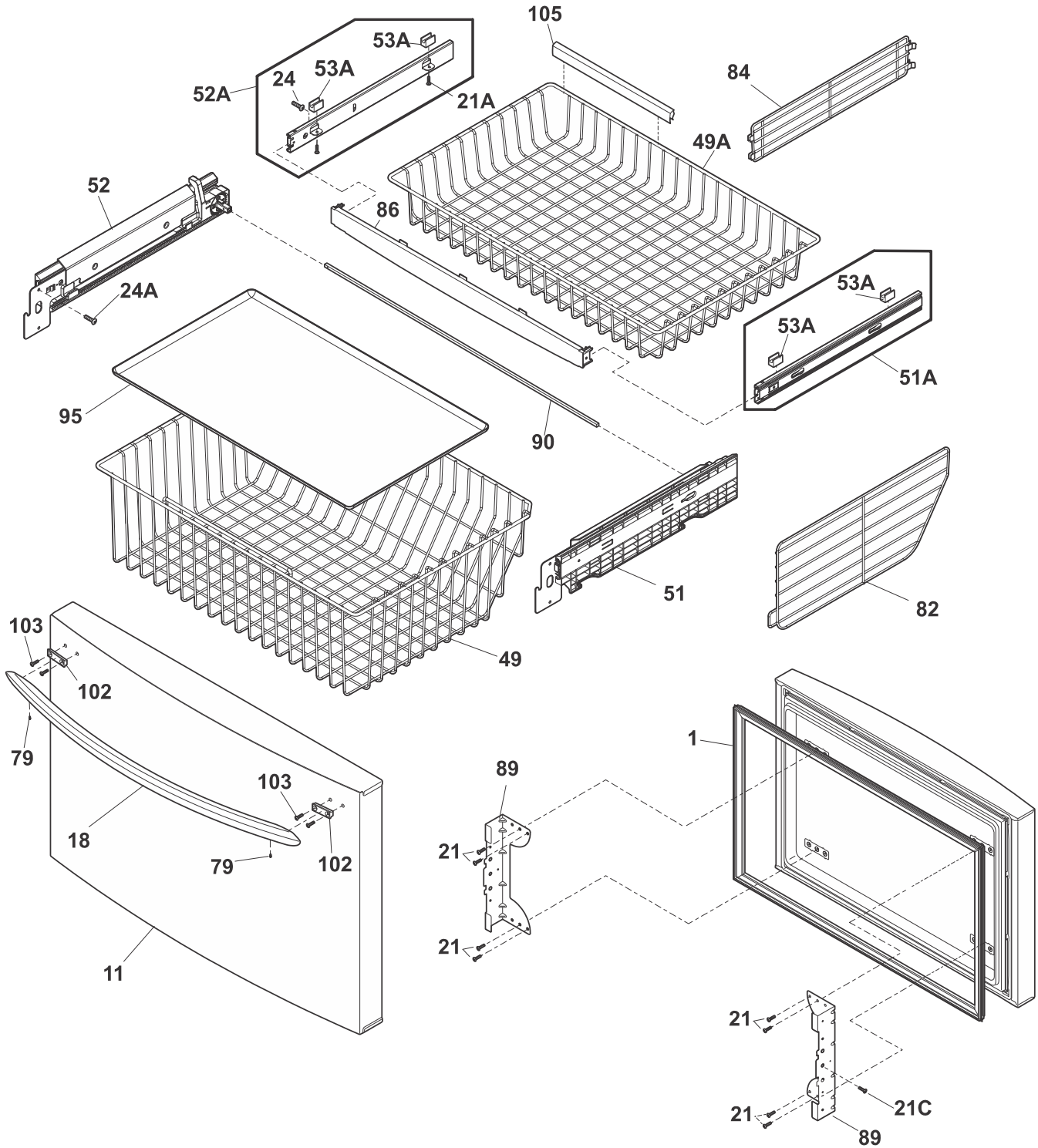

FDFGHN2844LEA

FREEZER DRAWER, BASKETS

POS. NO	PART NO.	DESCRIPTION
1 #	241778308	Gasket-frzr drawer, gray, magnetic
11	241987921	Door-frzr, stainless, complete assy
18	242029401	Handle-door, stainless
18*	241601001	Wrench, allen
21	241690602	Screw, quadrex, #10-16 Hilo
21A	241953902	Screw, #8 - 18 X .380, 3
21C	241899703	Screw, truss head, #10-32 x 1/4, zinc
24	240383406	Screw, truss hd quad, #10-16 x .500, zinc
24A	240383412	Screw, truss hd quad, #10-16 x .750, zinc
49	242026801	Basket-frzr, lower
49A	241780810	Basket-frzr, upper
51	242130510	Slide Assembly, basket lower, RH, freezer drawer
51*	242039702	Screw, shoulder, #10-16, (2)
51A	241894223	Slide Assembly, basket, RH, freezer drawer
51A*	242039701	Screw, basket slides
52	242130509	Slide Assembly, basket lower, LH, freezer drawer
52A	241894224	Slide Assembly, basket, LH, freezer drawer
53A	242216301	Retainer-basket
79	218755407	Screw-set, 10-32 x 0.500
82	242026901	Divider, basket
82*	241999901	Guide, divider, plastic (ABS), lower
82*	241999902	Guide, divider, plastic (ABS), lower, LH
84	241780904	Divider, basket
86	241807605	Trim, drawer, stabilizer
86*	242011101	Pin-lock
89	241972302	Bracket-freezer drawer
89*	242147601	Plate, tapping
90	242136901	Bar-timing
95	241770808	Tray, spill guard
102	242029301	Block-handle mtg
103	242077302	Screw, #10 AB flat hd
105	242116801	Trim-basket
*	241953901	Screw, #8-18
*	242146401	Screw, ser hex wash hd, 1/4-20 x 5/8, (4)

FRESH FOOD DOOR

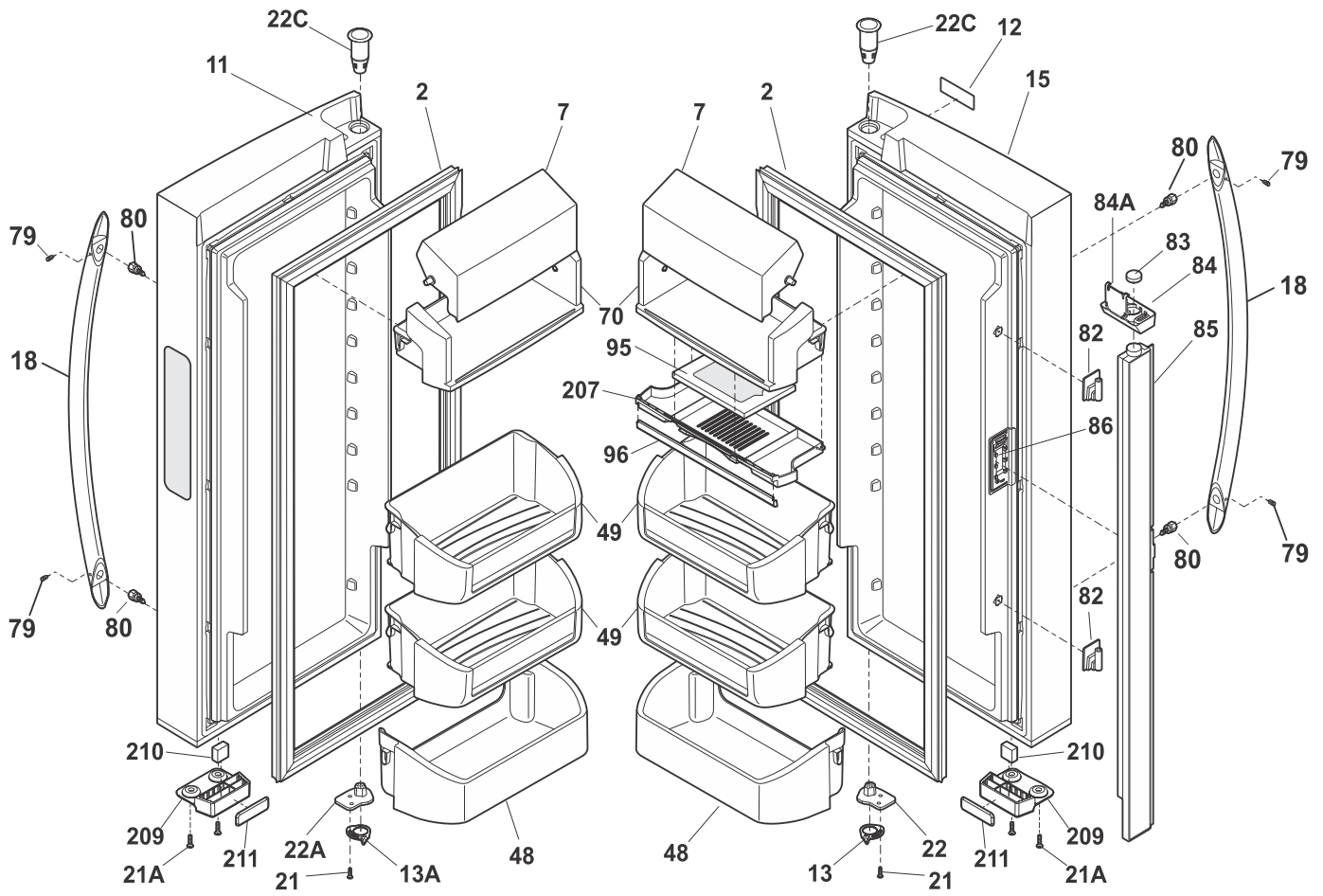

FFMSBH30V7LS2

FRESH FOOD DOOR

POS. NO	PART NO.	DESCRIPTION
2 #	241778307	Gasket-refr door, gray, magnetic
7	242011401	Door-dairy, removable
11	241988082	Door-refr, stainless, LH, non dispenser
12	137095500	Anchor, nameplate
13	241868401	Door Stop, refrig RH, plated
13A	241868402	Door Stop, refr LH, plated
15	241988081	Door-refr, stainless, RH
18	241930101	Handle-door, stainless
18*	241601001	Wrench, allen
21	242017501	Screw, 10-32 x 0.750
21A	241953901	Screw, #8-18
22	242075601	Cam, upper hinge, RH
22A	242075602	Cam, upper hinge, LH
22C	241760401	Bearing, hinge, top
48	242071401	Bin-door, pseudo, white
49	242037201	Bin-door, gallon
70	241804604	Compartment-dairy, removable
79	218755408	Screw-set, 10-32 x 0.375
80	218755504	Screw-shoulder, #10 AB, handle mounting
82	241779401	Hinge-mullion, upper/lower, flipper
83	241812202	Magnet, freezer drawer
84	242190401	Guide-mullion, magnet cover, flipper
84A	242190501	Cover-mullion, magnet cover
85	241778812	Flipper mullion assembly, w/heater
85*	242064001	Screw
85*	242068601	Bumper, flipper mullion
85*#	241788402	Harness-wiring, flipper mullion
86	241779801	Hinge-mullion, center, flipper
95	242047801	Filter-air
96	242048002	Door-air filter
207	242047901	Housing-air filter
209	242291001	Housing, magnet, white
210	241779101	Magnet, door
211	241979601	Bumper, rubber, white
*	242015001	Screw, 8-18 X 1/2
* #	242045401	Harness-wiring, door

CABINET

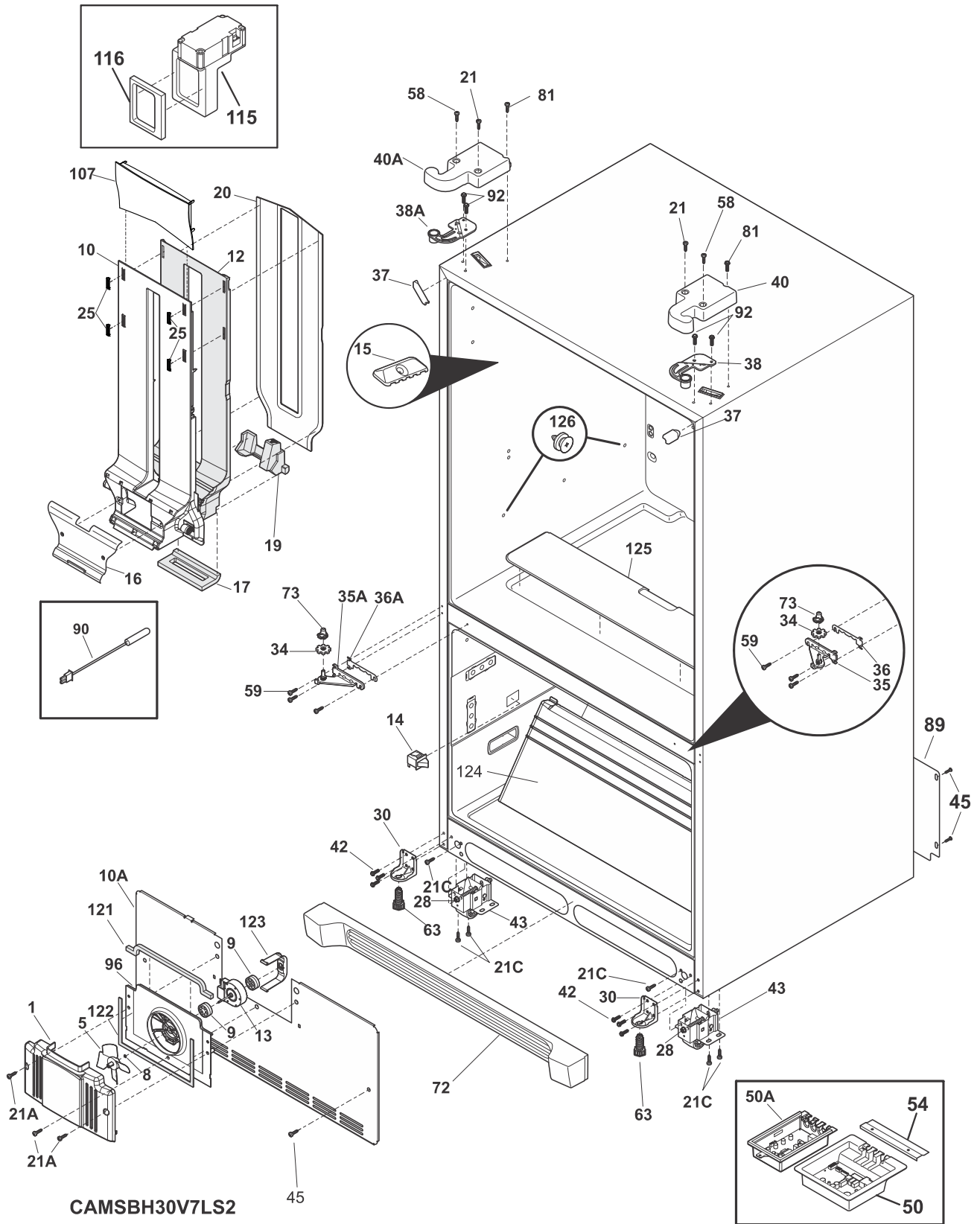

CABINET

POS. NO	PART NO.	DESCRIPTION
1	241859701	Cover-fan
5 #	5308000010	Fan Blade, red, evaporator fan
8	215474201	Washer, "slinger", nylon, evap fan shaft
9	241518301	Bushing, motor mounting
10	242072002	Cover-air duct
10*#	242061604	Harness-wiring, air duct
10*	242004802	Foam Strip
10A	241860402	Cover-evap coil, lower
10A*	241557601	Plug-hole, icemaker
10A*	241860104	Gasket-coil cover
10A*	241860105	Gasket-coil cover
12	242072402	Insulation-air duct
13 #	241509402	Motor, evaporator fan
14 #	240505801	Switch, light/lamp
15 #	241891104	Light-LED
16	242072101	Cover-damper
16*	240383407	Screw, truss hd quad, #10-16 x .500, white
16*	241953904	Screw, #8-18
16*	242072501	Cover-EPS, damper
17	242071901	Gasket-air duct/liner
19	242072601	Support-EPS damper
20	242072201	Cover-air duct, rear
21	241732101	Screw, 10-32 x 1/2
21A	242015001	Screw, 8-18 X 1/2
21C	218252201	Screw, #8 truss hd, 10-32CA x 0.500
25	241949502	Clip, air vent
28	240335502	Bolt-roller adj, hex washer head, 1/4-20 x 4.020, (2), special
30	241778701	Bracket-anti tip
34	241868301	Washer, hinge, nylon, (2)
35	241763005	Hinge-lower, zinc, RH
35A	241763006	Hinge-lower, zinc, LH
36	241868201	Spacer, door, lower RH
36A	241868202	Spacer, door, lower LH
37	240337614	Trim-cabinet corner, silver mist, (2)
38	241761301	Bracket-upper hinge, RH
38A	241761302	Bracket-upper hinge, LH
40	242099809	Cover-upper hinge, gray, RH
40A	242099810	Cover-upper hinge, gray, LH
42	240578902	Screw, hex head, 1/4-20 x 5/8
43	240335006	Roller Assy, front, (2)
45	241500303	Screw, hex washer head, 8-18AB x 1/2
50 #	241996341	Board-main power, 220
50*#	242068401	Harness-wiring
50A*	241852501	Clip, wiring harness
50A#	241891603	Board-LED power
54	241532401	Channel
58	241853202	Screw
59	240442706	Screw-#10-32 X 3/4, zinc
63	216396900	Screw, leveling foot, plastic, adjustable
72	242054801	Grille/Kickplate
73	242075701	Cam-lower hinge

CABINET

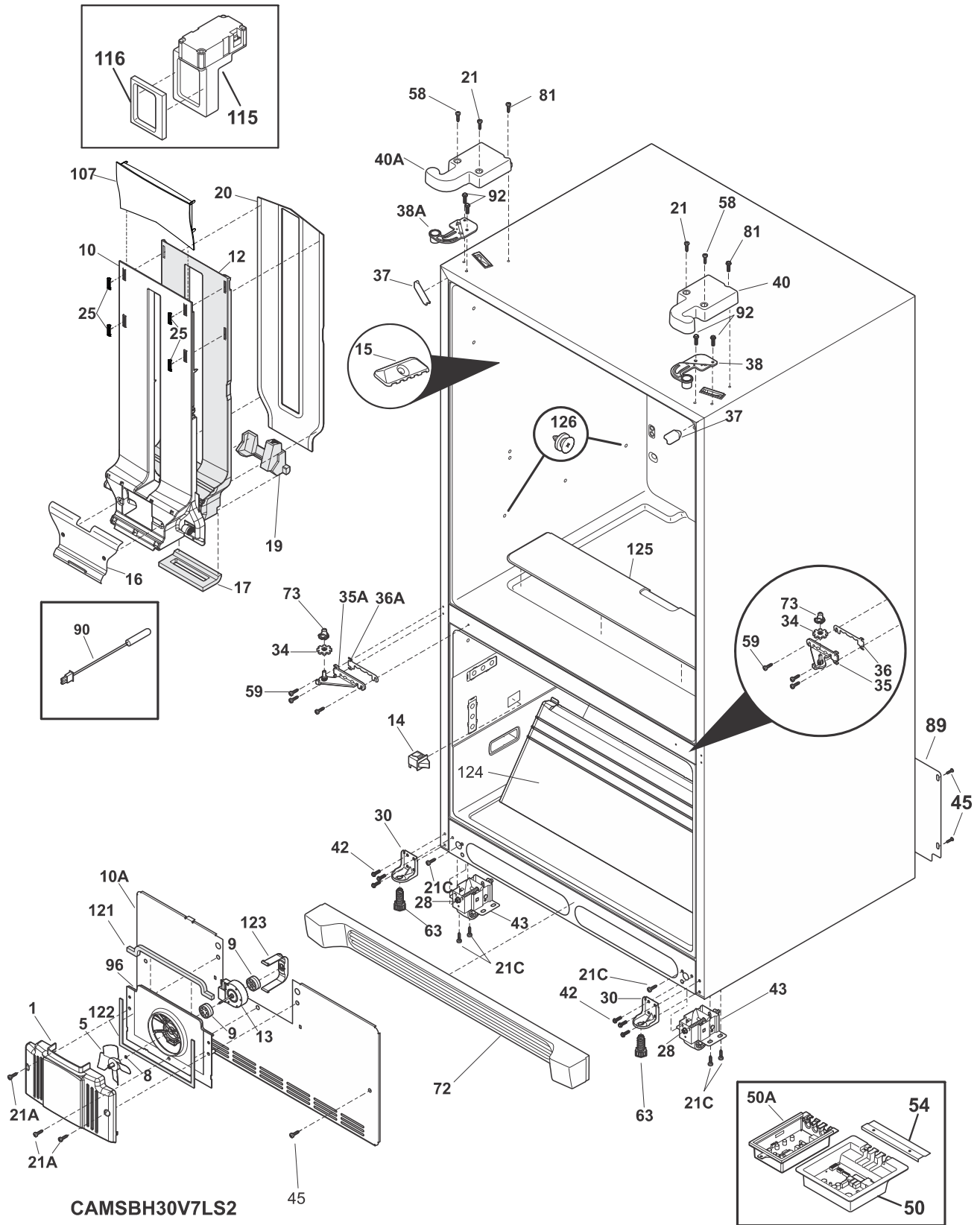

CABINET

POS. NO	PART NO.	DESCRIPTION
81	242025601	Screw, hex head, #10-32 x 3/8
89	241736406	Cover-access, with label
90	240597203	Sensor, temperature, 10K, NTC
90*	241842301	Cap-thermistor
90*	241953902	Screw, #8 - 18 X .380, 3
90*	241969001	Cap, screw
92	241710601	Screw, hex washer hd, 1/4 x 7/8, hinge mtg
96	241860601	Shroud-evap fan mtg
107	241963102	Duct-air, top
115	241518501	Damper, motorized
116	241518601	Seal-damper, foam
121	241860103	Gasket-evap, upper
122	241860102	Gasket-evap, bottom
123	242135301	Clip, evap fan motor, evap fan motor
124	242006902	Duct-air, freezer
125	242071201	Cover, sump
126	242081301	Screw-shoulder
*	240494001	Plug-button, white, cab liner holes
*	241695904	Screw
*	241953901	Screw, #8-18
*	5304455650	Screw, hex washer head, 8-15A x 0.625, Low Profile

SHELVES

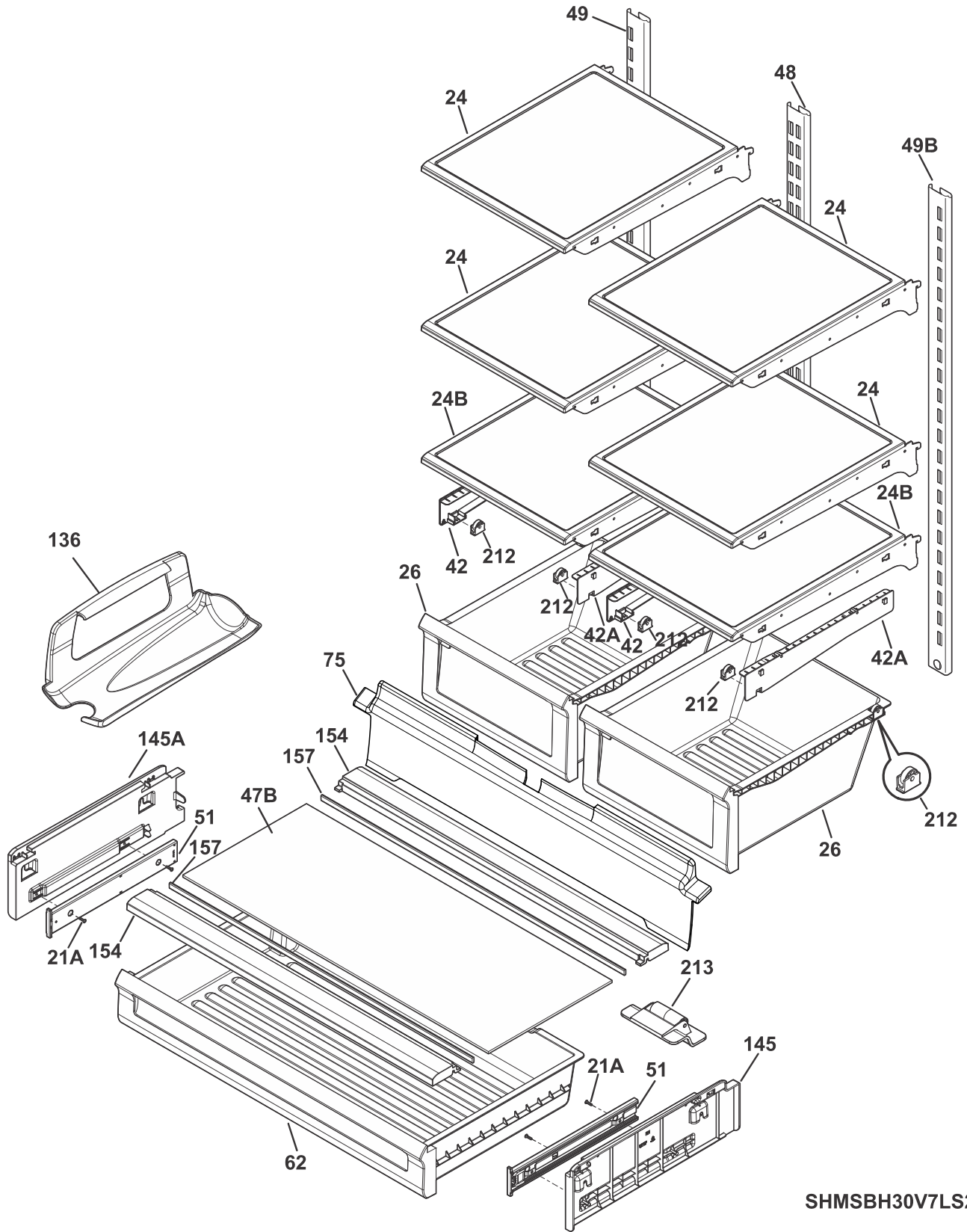

SHMSBH30V7LS2

SHELVES

POS. NO	PART NO.	DESCRIPTION
21A	241953902	Screw, #8 - 18 X .380, 3
24	242068701	Shelf-"Spill-Safe", cantilever, sliding
24B	242068703	Shelf-"Spill-Safe", fixed
26	241801802	Pan-crisper
26*	241695904	Screw
42	242067901	Support, crspr pan rolle
42*	241953901	Screw, #8-18
42A	242067801	Support, crspr pan rolle
47B	242082303	Glass, deli cover
48	242122101	Channel-shelf mtg, center
49	242122202	Channel-shelf mtg, side, LH
49B	242122301	Channel-shelf mtg, side, RH
51	242065301	Slide-deli
62	242096802	Pan-deli
75	242072702	Shield-light, refr
136	241657701	Dispenser-can, white
145	242082201	Support, rail
145A	242082202	Support, rail
154	242082401	Support
154*	242015001	Screw, 8-18 X 1/2
157	241872201	Beam-crisper cover
212	242236801	Roller Assembly, crisper pan
213	242010901	Roller Assy, deli pan
*	241500303	Screw, hex washer head, 8-18AB x 1/2
*	5304455650	Screw, hex washer head, 8-15A x 0.625, Low Profile

COOLING SYSTEM

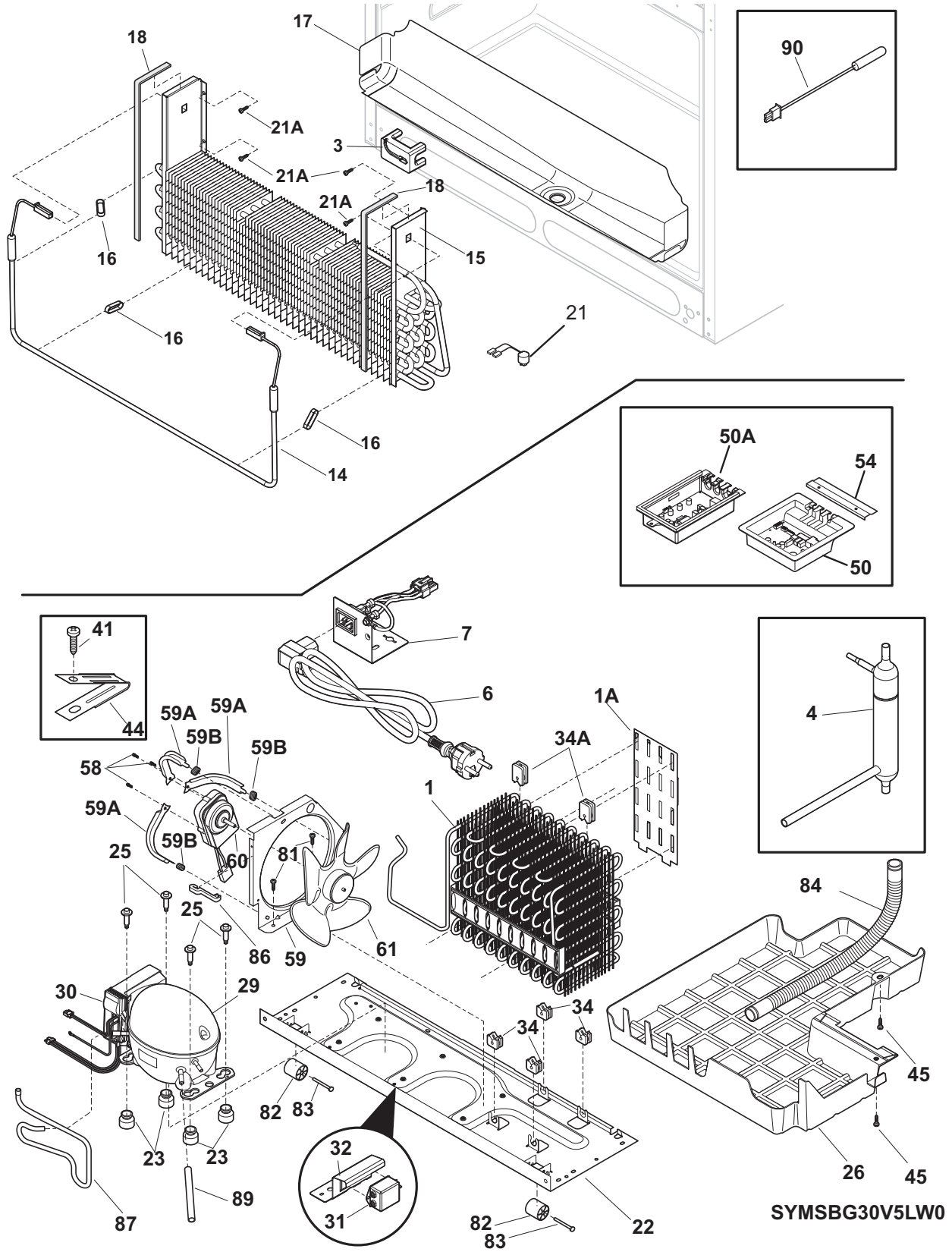

COOLING SYSTEM

POS. NO	PART NO.	DESCRIPTION
1 #	241862901	Condenser
1A	241987301	Deflector-air, condenser
3	241838401	Block-evap coil, styrofoam insul, RH
4 #	242047603	Dryer-filter
6 #	241723307	Cord-service, Britain
6* #	242045301	Harness-wiring, machine compt
7 #	241736102	Bracket, receptacle
14 #	240356227	Heater-defrost, 220 V
15 #	242044501	Evaporator
16	5308000110	Strap-evap/heater, aluminum, (2)
17	241791201	Trough-drain
18	241860101	Gasket, closed cell
21 #	242121701	Thermostat-defrost
21*#	242121702	Thermostat-defrost
21A	218362501	Screw, hex washer head, 8-18AB x 1.250, spacer, (2)
22	241602112	Base-compressor, w/rollers
22*	218252201	Screw, #8 truss hd, 10-32CA x 0.500
23	218513300	Grommet-compr mtg, (4)
25	240491503	Screw-compressor mtg, 1/4-28 x 1.16, (4)
26	241920603	Pan-defrost
29 #	241706206	S/A PUR-COMPRESSOR-EMBRACO
30	241577507	Invertor
31 #	241980401	Filter, electrical, EMC
31*#	241980201	Harness-wiring, EMC FILTER, EMC FILTER
32	242052801	Bracket, filter mounting
32*	240433204	Screw, hex washer head, 8-18 x 5/16
34	241929901	Grommet-cond mtg, (4)
34A	241929902	Grommet-cond mtg, (4)
41	240555002	Screw-#8-32 X 3/8
44	215174700	Clamp-service cord, strain relief, galv steel
45	5304455650	Screw, hex washer head, 8-15A x 0.625, Low Profile
50 #	241996341	Board-main power, 220
50*#	242068401	Harness-wiring
50A*	241852501	Clip, wiring harness
50A#	241891603	Board-LED power
54	241532401	Channel
58	240569202	Screw, 8-18 X .500
59	240315506	Shroud-cond fan, cond fan motor
59*	240346701	Tape-foam seal, shroud
59A	240346502	Bracket-support, cond mtr, (3)
59B	240346601	Grommet-bracket, (3)
60 #	241657102	Motor-condenser fan
61	241639501	Blade-condenser fan
81	240359403	Screw-fan shroud, (2)
82	5304418225	Roller, compressor base, rear, (2)
83	5304455655	Rivet, flat head, 1/4 OD x 1-3/4, roller pin
84	241830902	Tube-drain, lower
84*	242036801	Clip-tube, drain
86	240409302	Spacer-cond tube, black
87	241846302	Tube-suction, jumper
89	215346900	Tube-process
90	240597203	Sensor, temperature, 10K, NTC
*	3205266	Edge Protector, wiring harness
*	218515401	Clip-grille
*	241947701	Spacer, heat exchanger
*	5303918428	Hot Tube Repair Kit, service
* #	241510904	Harness-dispenser, grounding
* #	5303918445	Heat Exchanger Kit, suction line, service

CONTROLS

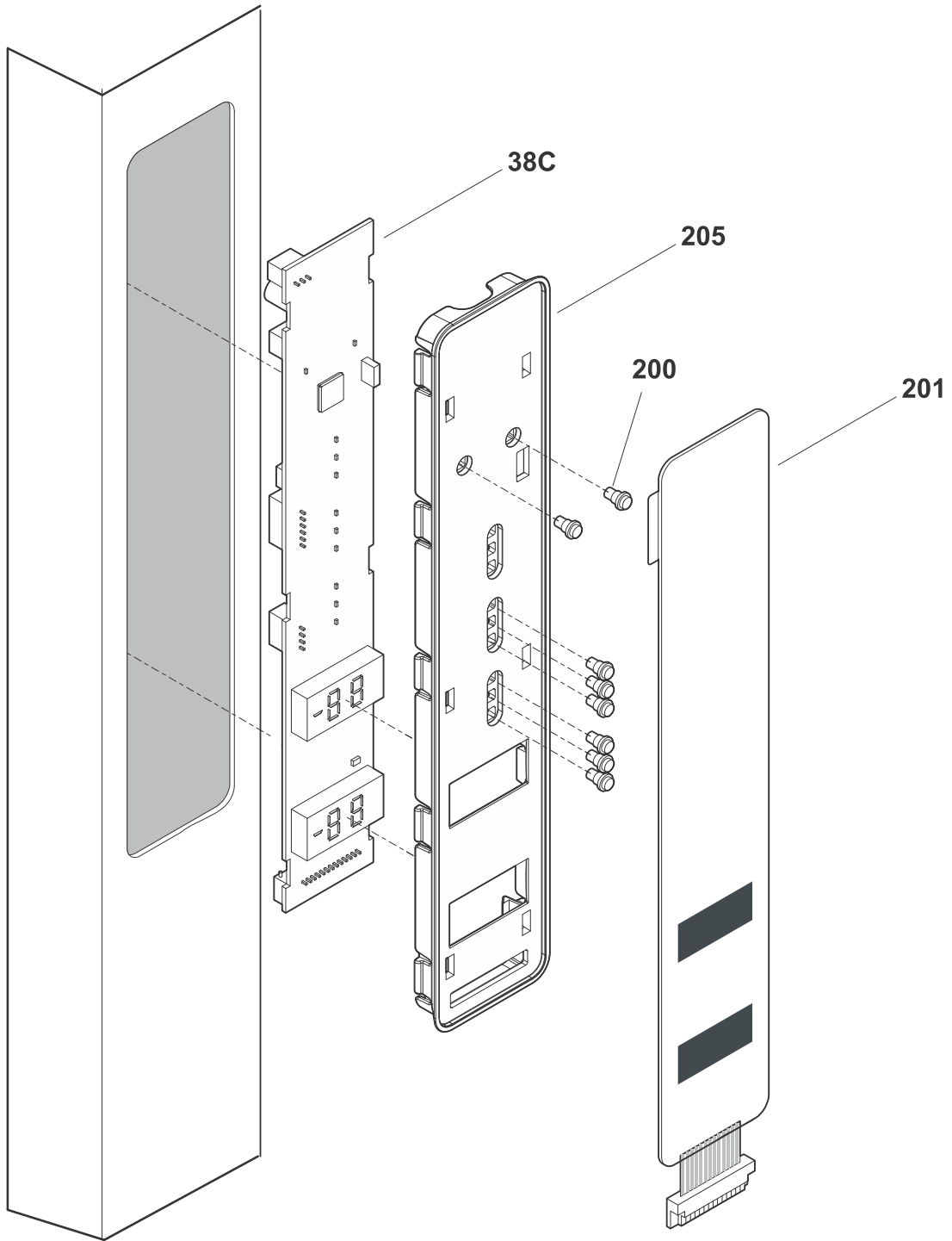

CTMSBH30V7LS2

CONTROLS

POS. NO	PART NO.	DESCRIPTION
38C#	242048305	Board-control, 38C#
200	241609201	Light Pipe
201	242129602	Switch-membrane
205	242066202	Housing, disp/controls
*	241510904	Harness-dispenser, grounding

WIRING DIAGRAM

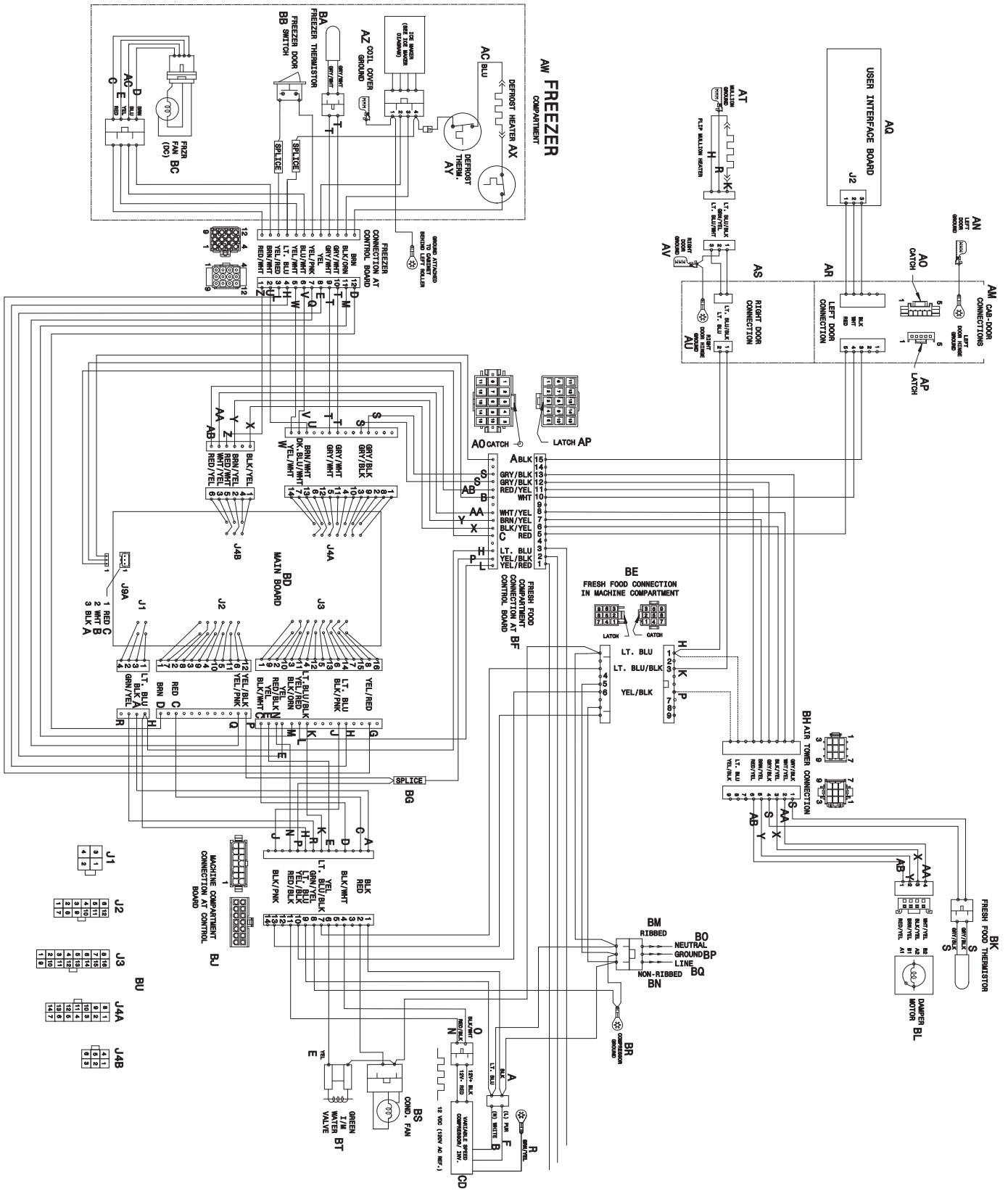

WIRING DIAGRAM

